

of a possibly wrong structure, the present determination was carried out.

Discussion. Needle-shaped crystals elongated along [010] were obtained from aqueous solution. Photographic examination confirmed the cell data published previously, and improved cell constants were obtained from measurements on a Stoe two-circle diffractometer with Mo radiation and a graphite-crystal incident-beam monochromator.

431 independent intensities with $2\theta \leq 60^\circ$ were recorded on the same instrument at an ω -scan rate of 4 s per 0.01° . The structure was solved by Fourier methods and refined by full-matrix least squares until all parameter shifts were less than 10% of the estimated standard deviations. R at the termination of refinement was 0.075. The final atomic and isotropic thermal parameters are listed in Table 1.*

Table 1. Positional and isotropic thermal parameters for NaSCN

	x	y	z	$B (\text{\AA}^2)$
Na	0.3919 (3)	0.25	0.9337 (7)	3.02 (8)
S	0.1856 (2)	0.25	0.1137 (4)	2.65 (6)
C	0.1127 (6)	0.25	0.8758 (15)	2.42 (14)
N	0.0627 (6)	0.25	0.7066 (14)	2.99 (15)

The structure is shown in Fig. 1. All atoms occur in the mirror planes at $y/b = \frac{1}{4}, \frac{3}{4}$. The SCN ions are linear within experimental error. The bond lengths are: $d(\text{S}-\text{C}) = 1.663$ (9) and $d(\text{C}-\text{N}) = 1.168$ (18) \AA . The angle at the C atom is 179.0 (8°). The packing is essentially as proposed before, and each Na^+ ion is octahedrally surrounded by three S and three N atoms in *fac* arrangement as shown in Fig. 2.

* A list of structure factors has been deposited with the British Library Lending Division as Supplementary Publication No. SUP 31314 (5 pp.). Copies may be obtained through The Executive Secretary, International Union of Crystallography, 13 White Friars, Chester CH1 1 NZ, England.

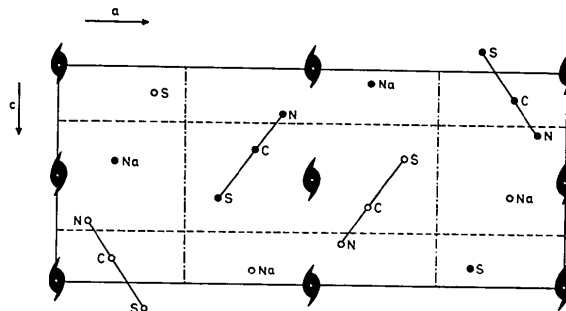

Fig. 1. The structure of NaSCN in (010) projection. Open circles represent atoms in the mirror plane at $y = \frac{1}{4}$ and solid circles atoms at $y = \frac{3}{4}$.

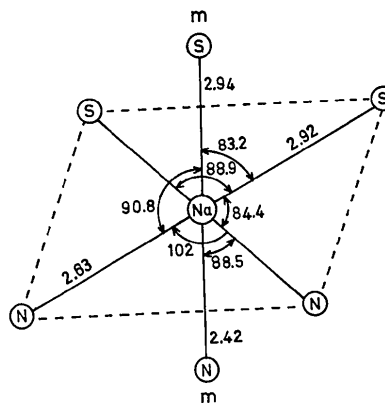

Fig. 2. Schematic drawing of the octahedral coordination sphere of a sodium ion.

References

- IQBAL, Z. (1971). *J. Mol. Struct.* **7**, 137-146.
 IQBAL, Z. (1972). *Struct. Bond.* **10**, 25-55.
 PISTORIUS, C. W. F. T. & BOEYENS, J. C. A. (1968). *J. Chem. Phys.* **48**, 1018-1022.

Acta Cryst. (1975). **B31**, 2934

1,3,5-Triacetyl-2,4,6-hexahydro-s-triazine (TRAT)

BY C. S. CHOI

Feltman Research Laboratory, Picatinny Arsenal, Dover, N.J., 07801, U.S.A. and Institute for Materials Research, National Bureau of Standards, Washington D.C., 20234, U.S.A.

A. SANTORO

Institute for Materials Research, National Bureau of Standards, Washington D.C., 20234, U.S.A.

AND P. L. MARINKAS

Feltman Research Laboratory, Picatinny Arsenal, Dover, N.J., 07801, U.S.A.

(Received 7 July 1975; accepted 30 July 1975)

Abstract. $\text{C}_9\text{H}_{15}\text{N}_3\text{O}_3$, monoclinic, $P2_1/c$, $a = 7.772$ (2), $b = 15.521$ (4), $c = 10.101$ (2) \AA , $\beta = 116.34$ (2°), $Z = 4$, $D_x = 1.30$, $D_m = 1.31$ g cm^{-3} , $F(000) = 456$. All X-ray

measurements were made with Mo $K\alpha$ radiation ($\lambda = 0.71069$ \AA). The structure was solved by direct methods and refined by full-matrix least-squares calculations to

final R and R_w values of 0.051 and 0.035, respectively, for 777 observed reflections.

Introduction. The reaction of hexamethylenetetramine with acetic anhydride produces bicyclo[3,3,1]nonanes (Siele, Warman & Gilbert, 1974) which are important intermediates in the synthesis of 1,3,5,7-tetranitro-1,3,5,7-tetraazacyclooctane, commonly called HMX and a well known explosive. Triacylhexahydro-*s*-triazines (I) are byproducts of this reaction. The compound 1,3,5-triacetyl-2,4,6-hexahydro-*s*-triazine [formula (I) in which $R = \text{CH}_3$], hereinafter called TRAT, is one of these byproducts.

Chemically, TRAT is related to cyclotrimethylene-trinitramine (II), commonly called RDX, a well known explosive whose crystal structure has been determined by X-ray and neutron diffraction techniques (Harris & Reed, 1959; Choi & Prince, 1972).

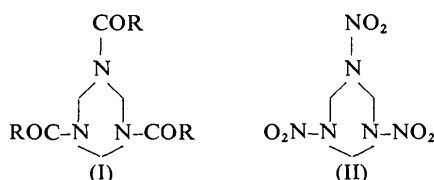

The stabilities of TRAT and RDX, however, differ greatly from one another and in order to compare the crystal and molecular structures of the two compounds the X-ray study of TRAT was undertaken.

Colorless crystals of TRAT were obtained from a chloroform solution saturated at 50°C and cooled to room temperature over a period of about 2 h. The crystals are highly hygroscopic and precautions have to be taken to avoid water absorption. The density was measured with an air pycnometer.

Crystal symmetry and approximate cell parameters were obtained with the precession method. The 2θ angles of 16 reflections in the range from 16 to 30° were measured with a diffractometer and the cell parameters were refined by least-squares analysis.

An irregularly shaped crystal of average diameter

of about 0.1 mm was enclosed in a capillary of Lindemann glass and was mounted on a three-circle diffractometer equipped with a Si(Li) solid-state detector (Hubbard, 1973). Intensities were measured with the 2θ scan method (scan interval $\Delta(2\theta) = 2.1 + \tan \theta$) for all reflections in a hemisphere having $2\theta \leq 55^\circ$. 4864 reflections were determined. The intensities of two standard reflections (404 and 080), measured periodically, decreased slightly during data collection. A correction for this effect was therefore applied to the experimental data. Intensities with $I < 4\sigma(I)$ were considered 'unobserved'. Equivalent reflections were merged into a unique set of 2484 reflections of which 1707 were unobserved. The intensities were corrected for Lorentz and polarization factors, but no absorption correction was applied owing to the irregular shape of the sample and to the small linear absorption coefficient of the material ($\mu = 1.06 \text{ cm}^{-1}$).

The structure amplitudes were converted to normalized structure factors E by a least-squares fit of the isotropic bulk temperature factor to the Wilson plot. The signs of 140 reflections with $E \geq 1.0$ were determined with the PHASE program of the X-RAY system (Stewart, 1972). An E map calculated with these signs revealed the heavy-atom positions.

Full-matrix least-squares refinement of the heavy atoms with isotropic temperature factors gave a conventional R value of about 14%. The function minimized was $\sum w(|F_o| - |F_c|)^2$ where w are the weights calculated from counting statistics. The scattering factors used in this and in the following refinements are those given by Cromer & Mann (1968). The positions of the H atoms present in the structure were located at this stage in a difference Fourier synthesis. The structure was then refined by including the H atoms with isotropic temperature factors. Secondary extinction corrections (Zachariasen, 1968) were applied in the last stages of refinement (the isotropic secondary extinction parameter r^* in $F_{\text{corr}} = F_c(1 + \beta r^* F_o^2)^{-1/4}$ was refined to 0.15×10^{-6}).

After the final cycle of refinement the R values for

Table 1. Final least-squares parameters for the structure of TRAT

The thermal parameters for the heavy atoms have the form $\exp \{-\frac{1}{4}[B_{11}(a^*h)^2 + B_{22}(b^*k)^2 + B_{33}(c^*l)^2 + 2(B_{12}a^*b^*hk + B_{13}a^*c^*hl + B_{23}b^*c^*kl)]\}$. Fractional coordinates are $\times 10^4$ for heavy atoms and $\times 10^3$ for H.

	x	y	z	B_{11}	B_{22}	B_{33}	B_{12}	B_{13}	B_{23}
C(1)	7123 (4)	4329 (2)	4341 (4)	4.3 (2)	4.7 (2)	4.3 (2)	-0.8 (2)	1.7 (1)	0.4 (2)
C(2)	5627 (5)	3043 (2)	3033 (4)	4.7 (2)	3.6 (2)	5.1 (2)	-0.7 (1)	2.1 (2)	-0.1 (2)
C(3)	3685 (4)	4260 (2)	2991 (4)	4.2 (2)	6.1 (2)	5.0 (2)	-0.4 (2)	2.7 (2)	-1.0 (2)
C(4)	5265 (5)	5591 (2)	2807 (4)	4.4 (2)	3.3 (2)	6.2 (2)	0.1 (2)	2.0 (2)	0.0 (2)
C(5)	8554 (4)	3639 (2)	2910 (4)	3.2 (1)	4.5 (2)	4.5 (2)	0.9 (1)	1.0 (1)	0.1 (2)
C(6)	2958 (5)	3427 (2)	677 (4)	4.3 (2)	4.8 (2)	3.9 (2)	-0.2 (2)	1.8 (2)	0.3 (2)
C(7)	7110 (5)	6065 (2)	3187 (4)	5.4 (2)	4.6 (2)	6.7 (2)	0.3 (1)	3.3 (2)	0.5 (2)
C(8)	8565 (5)	2901 (2)	1943 (4)	6.0 (2)	5.9 (2)	8.2 (3)	-0.2 (2)	3.9 (2)	-1.4 (2)
C(9)	1311 (5)	4032 (2)	-174 (4)	5.6 (2)	7.0 (3)	6.9 (3)	1.2 (2)	1.5 (2)	0.1 (2)
N(1)	5380 (3)	4815 (2)	3469 (3)	3.4 (1)	4.5 (2)	4.5 (2)	-0.6 (1)	1.8 (1)	-1.1 (1)
N(2)	7301 (3)	3594 (2)	3531 (3)	3.7 (1)	3.6 (1)	4.5 (2)	-0.4 (1)	1.6 (1)	-0.5 (1)
N(3)	3880 (3)	3538 (2)	2154 (3)	3.4 (1)	3.8 (1)	4.7 (2)	-0.3 (1)	1.8 (1)	-0.4 (1)
O(1)	3725 (4)	5894 (2)	2021 (3)	5.1 (1)	5.2 (2)	12.8 (2)	1.4 (1)	1.2 (1)	1.4 (1)
O(2)	9649 (3)	4243 (1)	3147 (3)	4.6 (1)	5.7 (1)	8.1 (2)	-1.9 (1)	3.4 (1)	-1.7 (1)
O(3)	3414 (3)	2862 (2)	53 (3)	7.8 (2)	6.0 (2)	5.3 (1)	1.2 (1)	3.3 (1)	-0.8 (1)

Table 1 (cont.)

	<i>x</i>	<i>y</i>	<i>z</i>	<i>B</i>
H(1)	831 (3)	472 (1)	468 (2)	3.1 (6)
H(2)	697 (4)	406 (2)	524 (3)	5.8 (8)
H(3)	562 (3)	255 (1)	238 (2)	1.2 (5)
H(4)	551 (3)	278 (2)	394 (3)	3.6 (5)
H(5)	243 (4)	463 (2)	230 (3)	4.6 (7)
H(6)	355 (3)	403 (1)	387 (3)	2.7 (6)
H(7)	662 (4)	651 (2)	231 (3)	8.3 (9)
H(8)	812 (4)	570 (2)	309 (3)	5.5 (8)
H(9)	769 (4)	630 (2)	440 (4)	9.7 (9)
H(10)	763 (5)	305 (2)	65 (4)	11.9 (11)
H(11)	987 (4)	288 (2)	197 (3)	5.9 (8)
H(12)	851 (4)	236 (2)	246 (3)	7.0 (9)
H(13)	72 (4)	384 (2)	-112 (4)	6.8 (9)
H(14)	177 (5)	461 (2)	-9 (4)	9.4 (11)
H(15)	44 (5)	403 (2)	28 (4)	9.0 (11)

all the observed reflections were $R=0.051$ and $R_w=0.035$, where $R_w=[\sum w(F_o - |F_c|)^2 / \sum wF_o^2]^{1/2}$. The maximum and the average shift/error were 0.08 and 0.02, respectively. The final atomic parameters are given in Table 1.*

Discussion. A perspective view of the molecule of TRAT is shown in Fig. 1 and bond distances and angles are given in Fig. 2. A comparison with the molecule of RDX (Choi & Prince, 1972) shows that the general molecular features of RDX and TRAT are very similar.

The ring bond distances and angles are almost identical with one another (the maximum deviation from the average C-N bond distance of 1.45 Å is 0.01 Å and the maximum deviation from the average bond angle of 111° is 1°). The three ring N atoms are equally distant from the plane through the C atoms C(1), C(2) and C(3) (0.45 ± 0.02 Å). The torsional angles of the C-N bonds are 50.9°, -50.3°, 50.6°, -51.6°, 52.9° and -51.9° in the cyclic order N(1)-C(1)-N(2)-C(2)-N(3)-C(3)-N(1). These angles do not show any significant fluctuations in contrast to the corresponding torsional angles in the RDX molecule which were found to be 49.6°, -53.3°, 45.9°, -44.9°, 43.3° and -48.4°. Thus, the ring configuration in TRAT is almost undistorted from the ideal geometry of the free cyclohexane molecule with threefold symmetry (Kitaigorodsky, 1963). The ring bond distances of TRAT and RDX agree quite closely but the average ring bond angle in RDX is 112° with a maximum deviation of almost 4°.

The three acetamide groups are essentially planar with maximum deviations of the atoms from the mean plane of 0.02, 0.007 and 0.004 Å for the N(1), N(2) and N(3) acetamide groups, respectively. The corresponding bond distances and angles are very close in the three groups, with maximum deviations of 0.02 Å and

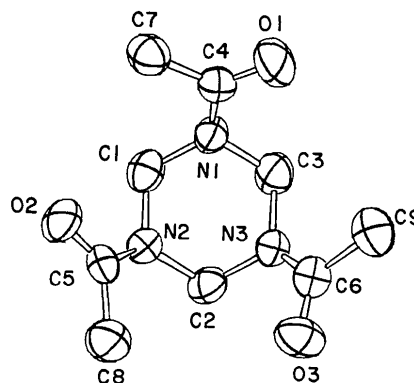

Fig. 1. Perspective view of the molecule of TRAT with thermal ellipsoids.

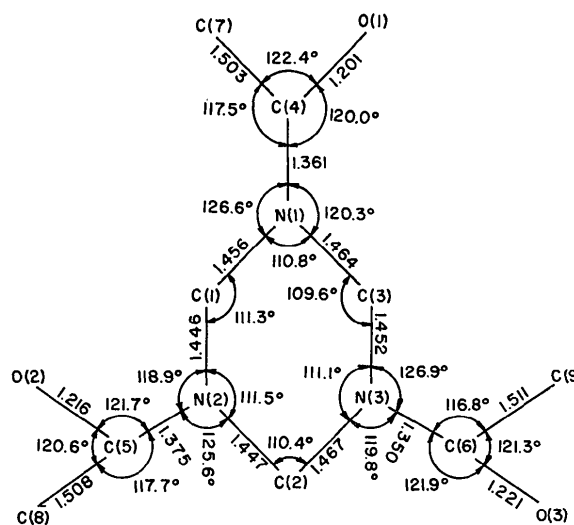

Fig. 2. Schematic illustration of the TRAT molecule with the unique bond distances and angles. The standard deviations are 0.004 Å and 0.4° on the bond distances and angles, respectively.

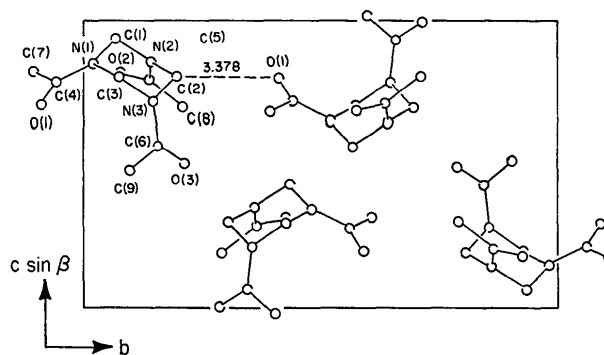

Fig. 3. Packing of the molecules in the crystal structure of TRAT. The figure is an orthogonal projection on the plane perpendicular to *a*.

* A list of observed and calculated structure factors has been deposited with the British Library Lending Division as Supplementary Publication No. SUP 31313 (13 pp., 1 microfiche). Copies may be obtained through The Executive Secretary, International Union of Crystallography, 13 White Friars, Chester CH1 1NZ, England.

2°. The two C atoms adjacent to each acetamide group deviate considerably from the mean plane of the respective group (deviations ranging from 0.14 to 0.36 Å).*

The acetamide groups are inclined to the plane through the C ring atoms by approximately the same angle (the average dihedral angle is 48° with a maximum deviation of only 2°). This geometrical configuration represents an interesting contrast to the highly distorted molecular shape of the RDX molecule in which the planes of the three nitro groups are inclined to the plane through the C ring atoms of angles ranging from 18° to 62°.

The observed C-H distances range from 1.01 to 1.08 Å for the ring C atoms and from 0.90 to 1.21 Å for the methyl groups.

Each ring C atom has short intramolecular contacts with the O and C atoms of the adjacent acetyl groups.

* A table of the atomic distances from the best fit mean planes of the acetamide groups has been deposited with the structure factor table (see previous footnote).

These distances, on average, are 2.73 Å for C...O contacts and 2.93 Å for C...C contacts.

Fig. 3 shows the molecular packing in the crystal of TRAT. The shortest intermolecular contacts are C(3)...O(2) = 3.21 Å along the *a* axis and C(2)...O(1) = 3.38 Å along the direction of the unique *b* axis. All other intermolecular contacts are larger than 4.3 Å.

References

- CHOI, C. S. & PRINCE, E. (1972). *Acta Cryst.* B28, 2857-2862.
 CROMER, D. T. & MANN, J. B. (1968). *Acta Cryst.* A24, 321-324.
 HARRIS, P. M. & REED, P. T. (1959). AFOSR-TR-59-165. Ohio State Univ. Research Foundation, Columbus, Ohio.
 HUBBARD, C. R. (1973). Abstr. F11, Amer. Cryst. Assoc. Winter Meeting, Univ. of Florida, Gainesville, Florida.
 KITAIGORODSKY, A. J. (1963). *Zh. Strukt. Khim.* 4, 163-166.
 SIELE, V. I., WARMAN, M. & GILBERT, E. E. (1974). *J. Heterocycl. Chem.* 11, 237-239.
 STEWART, J. M. (1972). *X-RAY System*. Technical Report TR-192, Computer Science Center, Univ. of Maryland, College Park, Maryland.
 ZACHARIASEN, W. H. (1968). *Acta Cryst.* A24, 212-216.

Acta Cryst. (1975). B31, 2937

The Monoacetate of *O*-Methylasparvenone*

BY MING CHAO AND ROBERT D. ROSENSTEIN

Department of Crystallography, University of Pittsburgh, Pittsburgh, Pennsylvania 15260, U.S.A.

AND PEI-DAWN LEE CHAO, PAUL L. SCHIFF JR, DAVID J. SLATKIN AND JOSEPH E. KNAPP

Department of Pharmacognosy, University of Pittsburgh, Pittsburgh, Pennsylvania 15261, U.S.A.

(Received 16 May 1975; accepted 4 August 1975)

Abstract. C₁₅H₁₈O₅, monoclinic, *P*2₁, *Z* = 2, *a* = 5.354 (2), *b* = 11.093 (2), *c* = 11.817 (2) Å, β = 91.53 (2)°, *D_m* = 1.31, *D_x* = 1.32 g cm⁻³. The structure was determined by direct and Patterson methods. The final *R* value over 1529 independent reflections is 4.6%. The molecule forms a strong intramolecular hydrogen bond with O(1)...O(8) distance 2.550 Å. O(4) on the asymmetric carbon C(4) is axial to the cyclohexanone ring. C(4), O(4), C(11), O(11) and C(12) are coplanar and the plane through them is almost perpendicular to the least-squares plane of the cyclohexanone ring.

Introduction. 7-Ethyl-3,4-dihydro-4,8-dihydroxy-6-methoxy-1-[2*H*]-naphthalenone (C₁₃H₁₆O₄, *O*-methylasparvenone) is one of the phenolic constituents isolated from *Aspergillus parvulus* Smith (Chao, Schiff, Slatkin, Knapp, Chao & Rosenstein, 1975). Since this compound had not previously been isolated or synthesized, its molecular structure was unknown. The monoacetate

derivative provided suitable single crystals for structure determination by X-ray analysis.

Pale brown, long needle-shaped crystals were grown by slow evaporation from ethanol solution. A crystal cut to approximate dimensions 0.2 × 0.2 × 0.3 mm was used. The precise lattice parameters and three-dimensional intensity data were derived by least-squares calculations from measurements on a four-circle computer-controlled Nonius CAD-4 diffractometer with graphite-monochromated Cu *K*α radiation and θ-2θ scan mode with θ ≤ 75°. Integrated intensities for 1529 independent reflections were collected, which yielded 66 weak reflections with integrated intensity less than 2σ(*I*). These reflections were assigned intensities of σ(*I*)/2 and given zero weight during the refinement. No corrections were made for absorption and extinction. All the intensity data were processed by routine methods (Shiono, 1971).

The structure was solved by a combination of direct and Patterson methods. The *MULTAN* program (Germain, Main & Woolfson, 1971) was applied to all reflections with |*E*| ≥ 1.5 after renormalization. The *E* synthesis calculated from the highest figure of merit

* This work was supported in part by the National Science Foundation, University Science Development Grant No. GU-3184.